

## 462250 - Bodentürschwelle Transit ausziehbar für Anschlagdichtung mit thermischer Trennung S=91-106mm H=34mm F1 L=5.000mm

### Technische Zeichnung

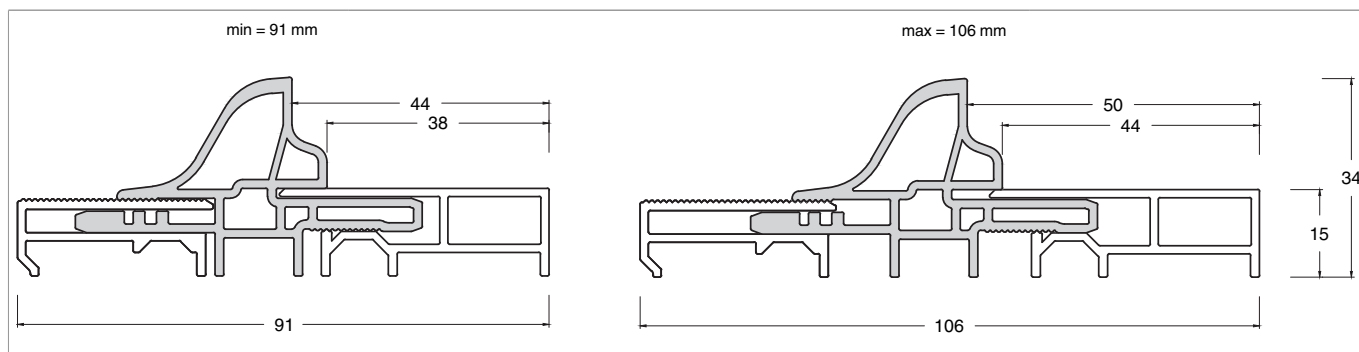

				<b>L</b>		<b>No</b>
	F1	34	91 - 106	5.000	1	<a href="#">462250</a>

### Anwendungsbereich

Schnitt Flügel

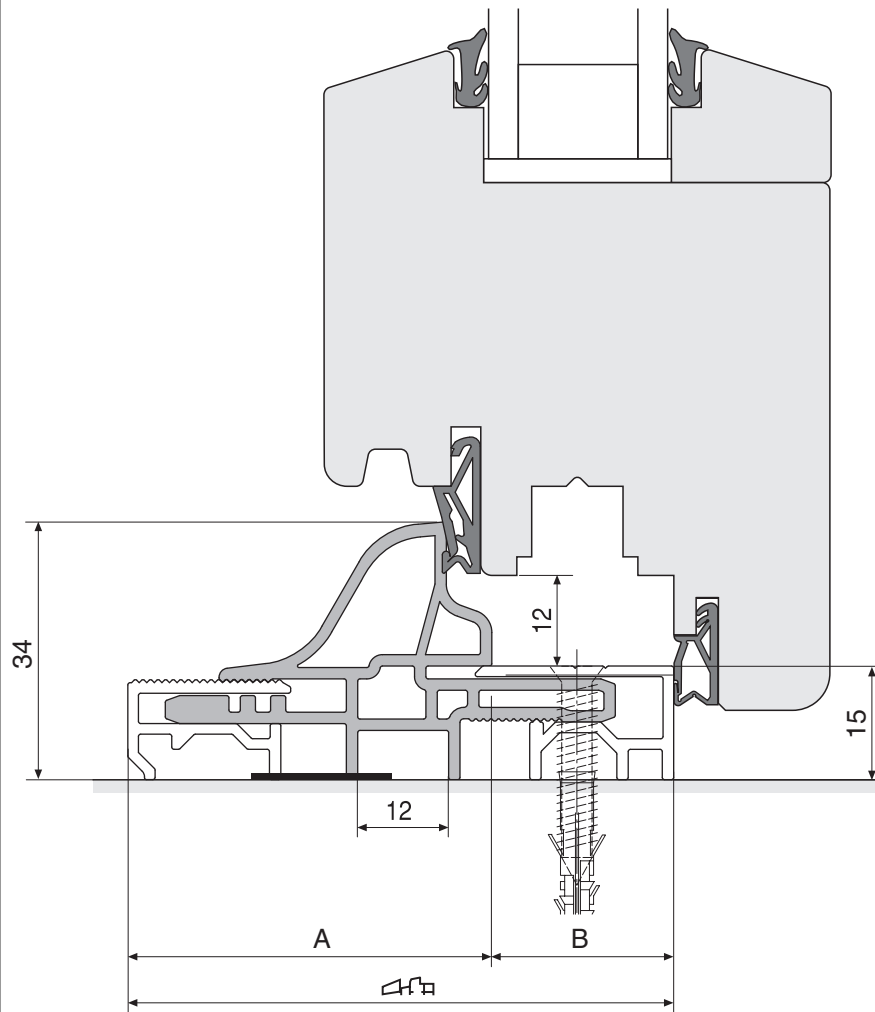

B = Falztiefe

	A [mm]	B [mm]
63-76	44-52	18-24
77-94	52-64	24-30
91-108	53-64	38-44

## Schnitt Stock

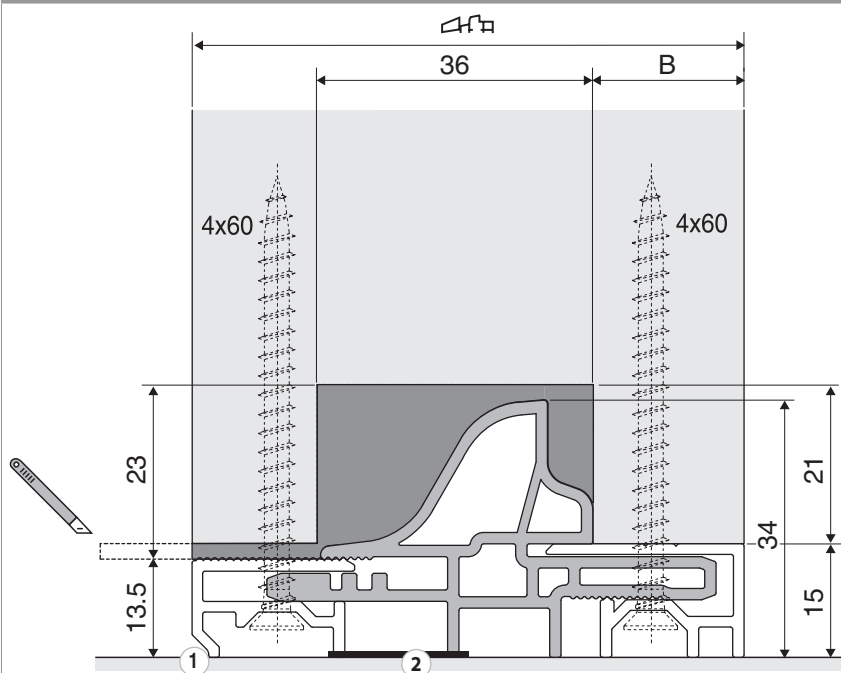

B = Falztiefe

1 = Abdichtung mit Silikon

2 = Abdichtung mit Butylband

## Montage Bodenschwelle mit Stock

## Schiene ablängen

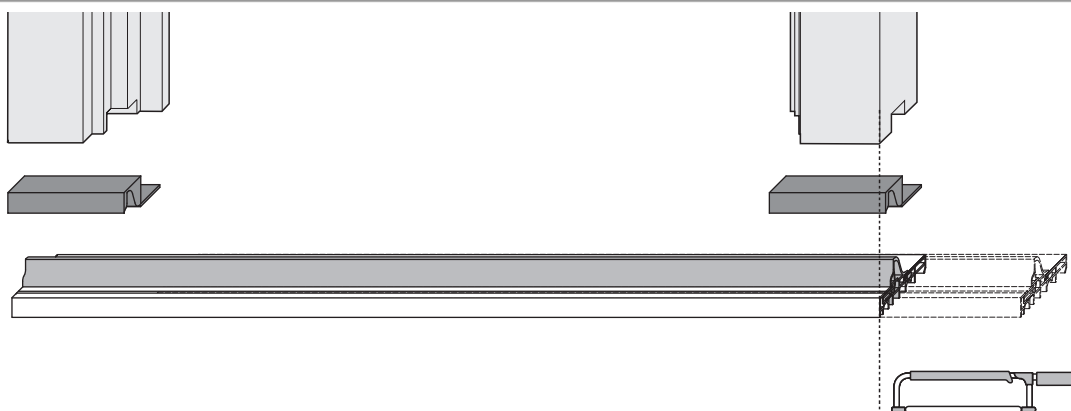

Breite der Schiene einstellen

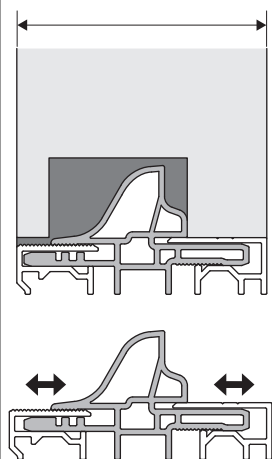

Gummiabdeckung an den Stock anpassen

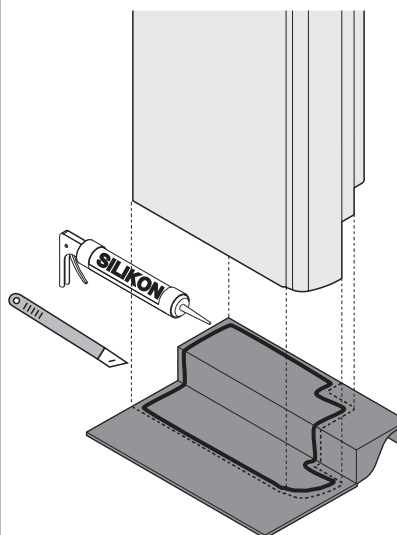

Gummiabdeckung montieren

