

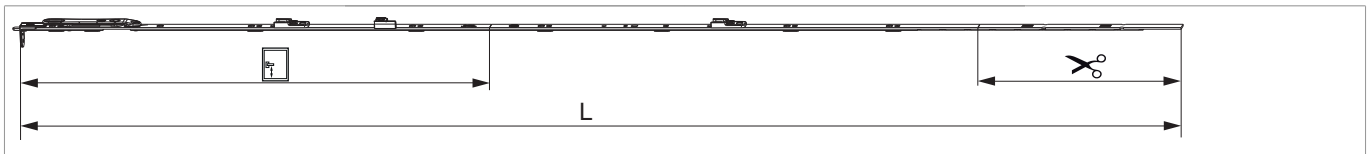







226636 - Stulpflügelgetriebe MM Euronut fix 1340 für 1 i.S. FFH 1.091-1.340 GM 500 Silber

Technische Zeichnung



				L				N^o
Silber	für 1 i.S.	1340	500	1.236,5	1.091 - 1.340	260	10	226636¹⁾

¹⁾Befestigungsklammer Art. Nr. 94035 + Stulpniederhalter Art. Nr. 94036 dazubestellen!

Schraubpositionstabelle

N^o		1	2	3	4	5	6	7	8	9	10	11	12	13	14	15	16	17
226636	7	38,5	176,5	400	540	684,5	750	861,5										



Stanzbild

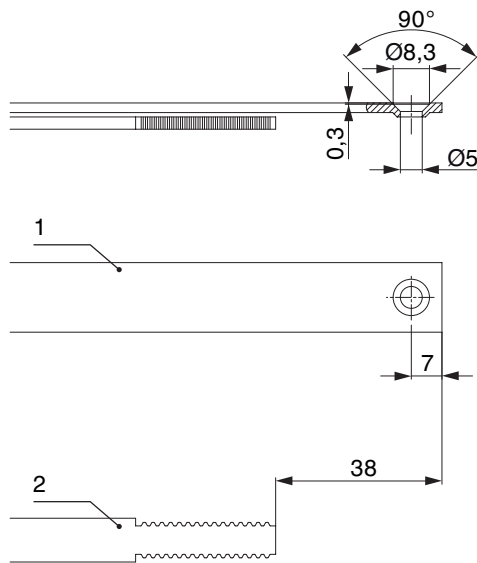

1. Stulp

2. Riegel

ACHTUNG: Mit geschlossenem Spreizhebel ablängen!

Stangenausschluss

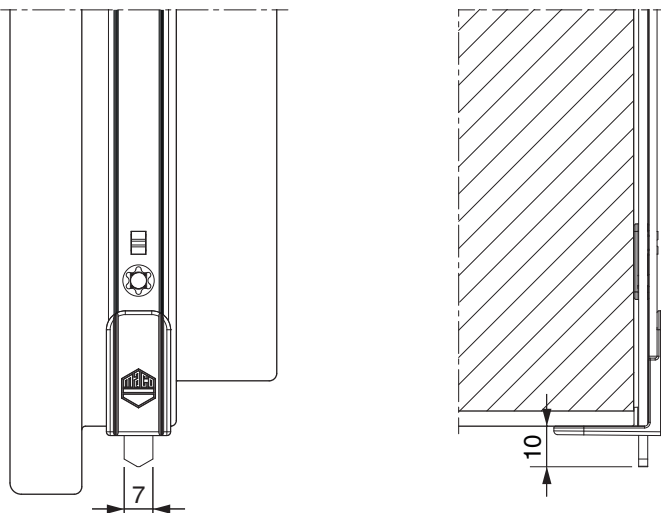

Gegenüberstellung der Kerbmarken

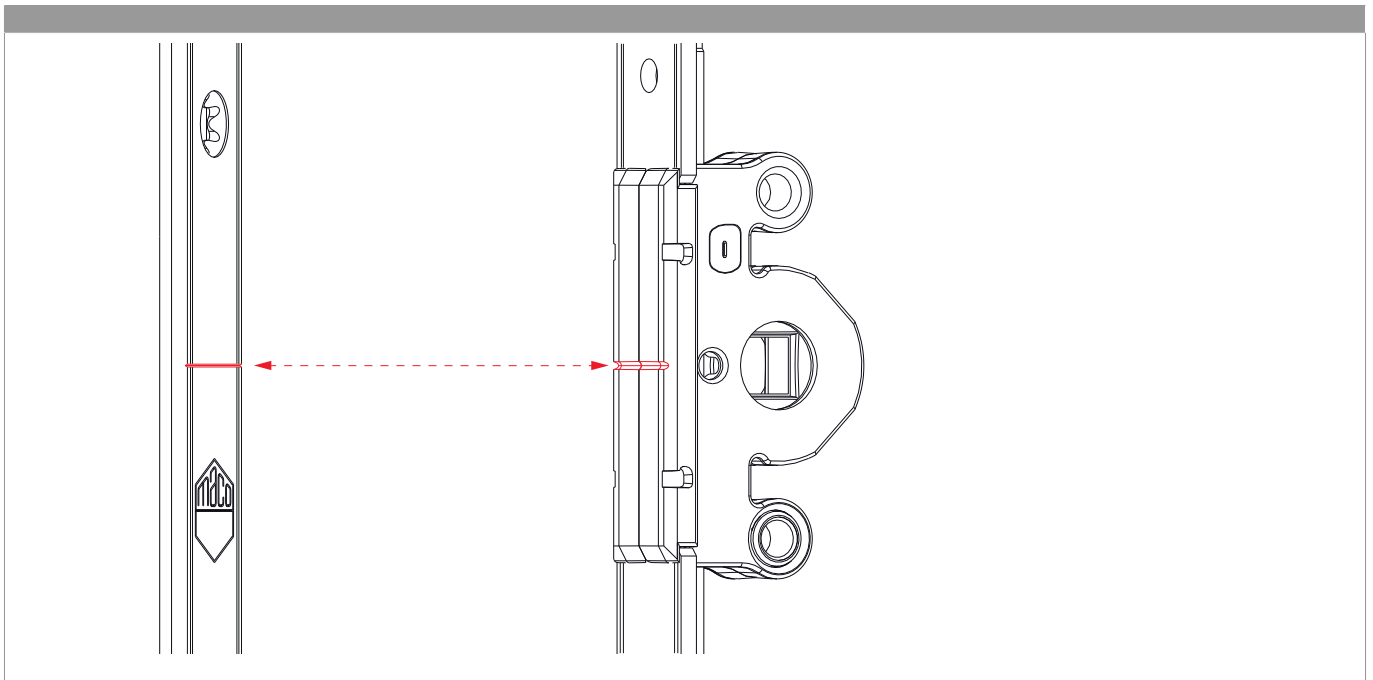

Anpressdruckregulierung

